

PT 20/25/30H PT20H PLUS

High-speed Logistic Center Special Version Lithium-ion Pallet Truck

H series is the special developed to meet the demand and characteristics of logistics and leasing industry. A variety of models can satisfy the working condition of heavy transport environment, such as PT20H/PT20HPLUS/PT25H/PT30H. 2000/2500/3000 kg load capacity, the highest speed of 12 km/h with high efficiency and it is suitable for long-distance transportation.

The battery doesn't rise when operating. It lowers energy consumption and makes the battery working time longer.

The drive system is with load-assisted pressure-adjust system, which improves the service life of the drive wheels and decreases the cost of using sliding frame and pull rod structure. The service life of structure is longer and the maintenance is more convenient and lower cost.

Standard high-performance lithium-ion batteries. The battery can be charged fast and there is no need for the maintenance. Moreover, it also has longer service life. Remote control module and the battery heating system are optional.

Rich model selection. H series are suitable for all kinds of working condition of demand. All trucks have electrical steering in this series that makes the operation flexible and easily except 20HPLUS.



EPT 20/25/30H

www.arasfze.com

High-speed Logistic Center Special Version Lithium-ion Pallet Truck



ARAS Developments FZE
JAFZ, Dubai- U.A.E.
T: 971 4 887 6602
E: sales@arasfze.com

ARAS
Handling Equipment



Type sheet for industrial truck acc. to VDI2198

Distinguishing mark

1.2	Manufacturer's type designation	PT 20H			EPT 20H PLUS			EPT 25H			EPT 30H		
		Foldable Platform	Enclosed fixed Platform	Fixed Platform	Foldable Platform	Enclosed fixed Platform	Fixed Platform	Foldable Platform	Enclosed fixed Platform	Fixed Platform	Foldable Platform	Enclosed fixed Platform	Fixed Platform
1.3	Drive	Battery			Battery			Battery			Battery		
1.4	Operator type	Stand			Stand			Stand			Stand		
1.5	Load capacity/Rated load	Q (t)			2.0			2.5			3.0		
1.6	Load center distance	c (mm)			600			600			600		
1.8	Load distance, the centre of drive axle to fork	x (mm)			895			895			895		
1.9	Wheelbase	y (mm)			1432			1432			1432		

Weight

2.1	Service weight	kg	730	800	750	730	800	750	730	800	750	730	800	750
2.2	Axle loading, laden front/rear	kg	975/1795	1040/1790	995/1795	975/1795	1040/1790	995/1795	1085/2145	1170/2140	1105/2145	1195/2495	1260/2490	1215/2495
2.3	Axle loading, unladen front/rear	kg	585/145	670/140	605/145	585/145	670/140	605/145	585/145	670/140	605/145	585/145	670/140	605/145

Tires, chassis

3.1	Tires	Polyurethane			Polyurethane			Polyurethane			Polyurethane			
3.2	Tire size, front	Øxw(mm)	Ø250X80			Ø250X80			Ø250X80			Ø250X80		
3.3	Tire size, rear	Øxw(mm)	Ø82X82			Ø82X82			Ø82X82			Ø82X82		
3.4	Additional wheels(dimensions)	Øxw(mm)	Ø124X60			Ø124X60			Ø124X60			Ø124X60		
3.5	Wheels,number front/rear(x=driven wheels)		1x+2/4			1x+2/4			1x+2/4			1x+2/4		
3.6	Tread, front	b10 (mm)	544			544			544			544		
3.7	Tread, rear	b11 (mm)	505			505			505			505		

Dimensions

4.4	Lift	h3 (mm)	120			120			120			120		
4.9	Height of tiller in drive position min./max.	h14 (mm)	1075/1375			1075/1375			1075/1375			1075/1375		
4.15	Height, lowered	h13 (mm)	85			85			85			85		
4.19	Overall length	l1 (mm)	1950	2383	2443	1950	2383	2443	1950	2383	2443	1950	2383	2443
4.20	Length to face of forks	l2 (mm)	800	1233	1293	800	1233	1293	800	1233	1293	800	1233	1293
4.21	Overall width	b1 (mm)	790			790			790			790		
4.22	Fork dimensions	s/e/1 (mm)	60/180/1150			60/180/1150			60/180/1150			60/180/1150		
4.25	Width across forks	b5 (mm)	685			685			685			685		
4.32	Ground clearance, centre of wheelbase	m2 (mm)	25			25			25			25		
4.33	Aisle width for pallets 1000X1200 crossways	Ast (mm)	2530	2960	3020	2530	2960	3020	2530	2960	3020	2530	2960	3020
4.34	Aisle width for pallets 800 x1200 lengthways	Ast (mm)	2415	2845	2905	2415	2845	2905	2415	2845	2905	2415	2845	2905
4.35	Turning radius	Wa (mm)	1710	2140	2200	1710	2140	2200	1710	2140	2200	1710	2140	2200

Performance data

5.1	Travel speed, laden/unladen	km/h	9/12			9/12			8/9			6/7		
5.2	Lift speed, laden/unladen	m/s	0.035/0.048			0.035/0.048			0.030/0.048			0.030/0.042		
5.3	Lowering speed, laden/unladen	m/s	0.040/0.025			0.040/0.025			0.045/0.025			0.040/0.025		
5.8	Max. gradeability, laden/unladen	%	6/15			8/15			6/15			6/15		
5.10	Service brake		Eletromagnetic			Eletromagnetic			Eletromagnetic			Eletromagnetic		

Electric engine

6.1	Drive motor rating S2 60min	kW	1.8			2.5			2.5			2.5		
6.2	Lift motor rating at S3 10%	kW	2.2			2.2			2.2			2.2		
6.3	Battery acc. to DIN 43531/35/36A,B,C,norm		/			/			/			/		
6.4	Battery voltage, nominal capacity K5	V/Ah	24V/150Ah (200)			24V/150Ah (200)			24V/150Ah (200)			24V/150Ah (200)		
6.5	Battery Weight	kg	75			75			75			75		
6.6	Energy consumption acc. to VDI cycle	KWh/h	0.55			0.65			0.75			0.65		

Additional data

8.1	Type of drive control		AC speed Control			AC speed Control			AC speed Control			AC speed Control		
8.4	Sound level at driver's ear acc. to EN 12053	dB(A)	69			69			69			69		

EPT 20/25/30H, EPT 20H PLUSoldable Platform

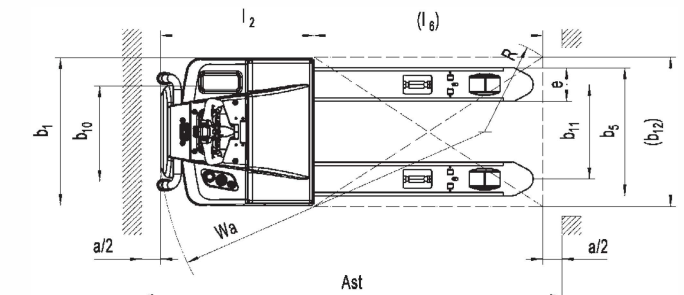
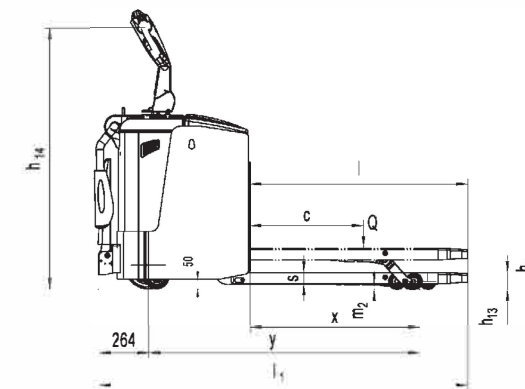

EPT 20/25/30H, EPT 20H PLUSnclosed fixed Platform

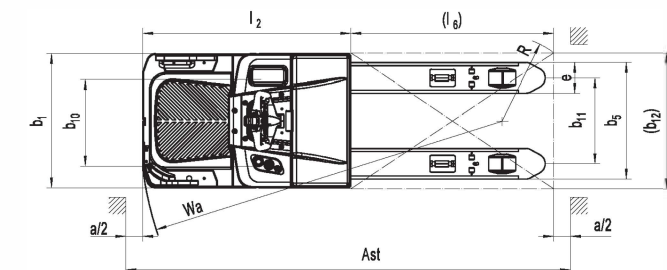
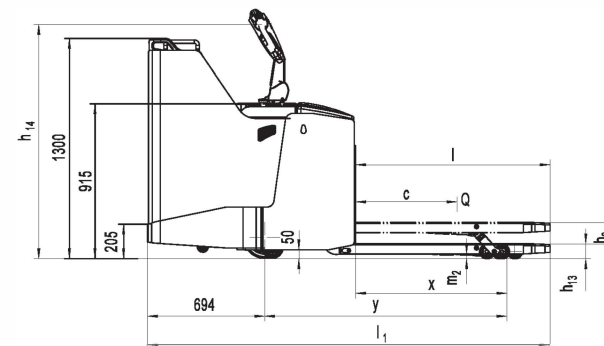

EPT 20/25/30H, EPT 20H PLUSixed Platform

