

LITHIUM PALLET TRUCK

24 HOURS
BUILT TO WORK



SMART POWERFUL DURABLE

BUILT TO WORK
24
HOURS

SMART SIZE

ALMOST SAME

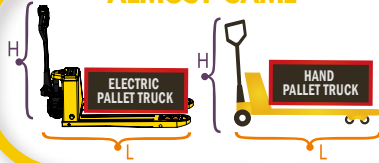

LIGHT WEIGHT



EFFICIENCY

3 Times Higher Than Manual Pallet Truck

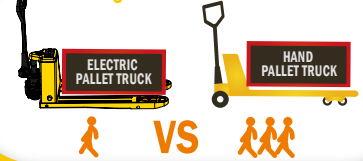

EASY MAINTENANCE

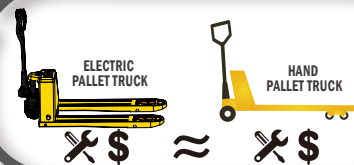

LIFETIME

3 Times Longer Than Manual Pallet Truck



1 PC VS 3 PCS

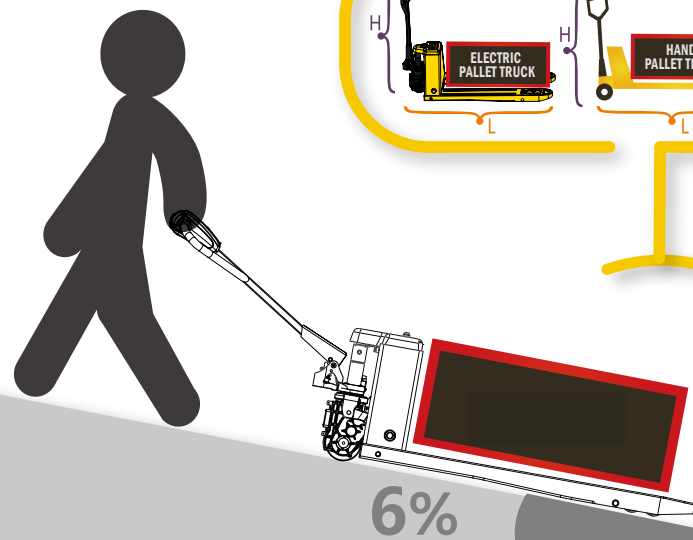

HIGH RETURN OF INVESTMENT

Safety

PRODUCTIVE

1 MONTH COST RECOVERY

Optimize your operations
SAVE LABOUR
Brake any time anywhere

Release manpower

Powerful With High Gradeability



Unique brushless technology

Brushless motor, powerful and maintenance free.
Leading in the industry.



750W/1000W power
Brushless motor
Maintenance free



Powered traveling



Powered lifting & lowering

Maintenance free

For brushed motor, carbon brush needs to be replaced every 12 or 18 months.
For EPT15H, no need to replace carbon brush.
Maintenance-free, saving maintenance time and cost.

Powerful with high gradeability

To easily move 1.5 ton or 2 ton over the slopes at warehouse entrances.



Traveling speed

— **UNLADEN** 4.5km/h
+ **LADEN** 4km/h

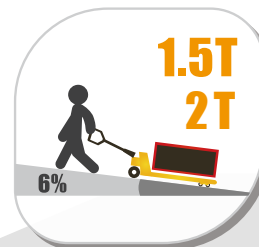
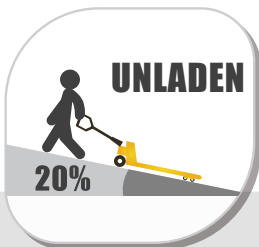

Gradeability



Non-stop Working

6s to replace battery

Maintenance-free lithium battery
It takes only 6s to replace battery.
With a spare battery, the unit can keep working 24 hours.

Ensured battery safety

Safe and reliable, no fire, no explosion.
Complying with IEC, UL global standard certification requirements, ensuring the safety of user property.

- Long service life: lithium battery with a long service life.
- High safety performance: it adopts soft package battery technology, built-in protection board and multiple protection to eliminate overcharge and overdischarge.
- Maintenance free: no need to add water.

Compact and durable

Solid build, no breaking

Chassis made by solid materials, no bending, no deformation.
Reinforced rocker arm, push rod, wheel frame and support seat.
No plastic part, less damage.

Most compact unit with same lifting capacity

Suitable for small workplaces such as compact workshops, trucks or vans, tail lifts or elevators.
EPT15H has the smallest turning radius among similar products.

Integral forks, no splicing

The forks are uniquely designed, easy to handle European pallets, American pallets and plastic pallets.
Solid fork with no deformation, far more durable than other brands of the same category.

Short charging time Charge and use freely

Quick charging: 2 hours to fully charge the battery.



Basic Configuration

Horn

Emergency reverse button

Forward/reverse butterfly switch

Lifting / Lowering

LCD Screen

- Battery indicator with hour meter
- Error code display
- Recharge alert



Multi-function Handle (Full Electric)

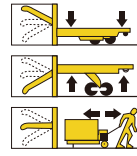

Multi-function Ergonomic Handle (Semi-electric)



Tandem/Single PU wheel



Low profile forks

Lowered fork height: 65mm
Standard model: 82mm



Lithium Battery



Protection cover
Protect the drive motor,
Anti-foot stamping



Intelligent charger



Electric lifting/lowering



Manual lifting/lowering

Dimensions

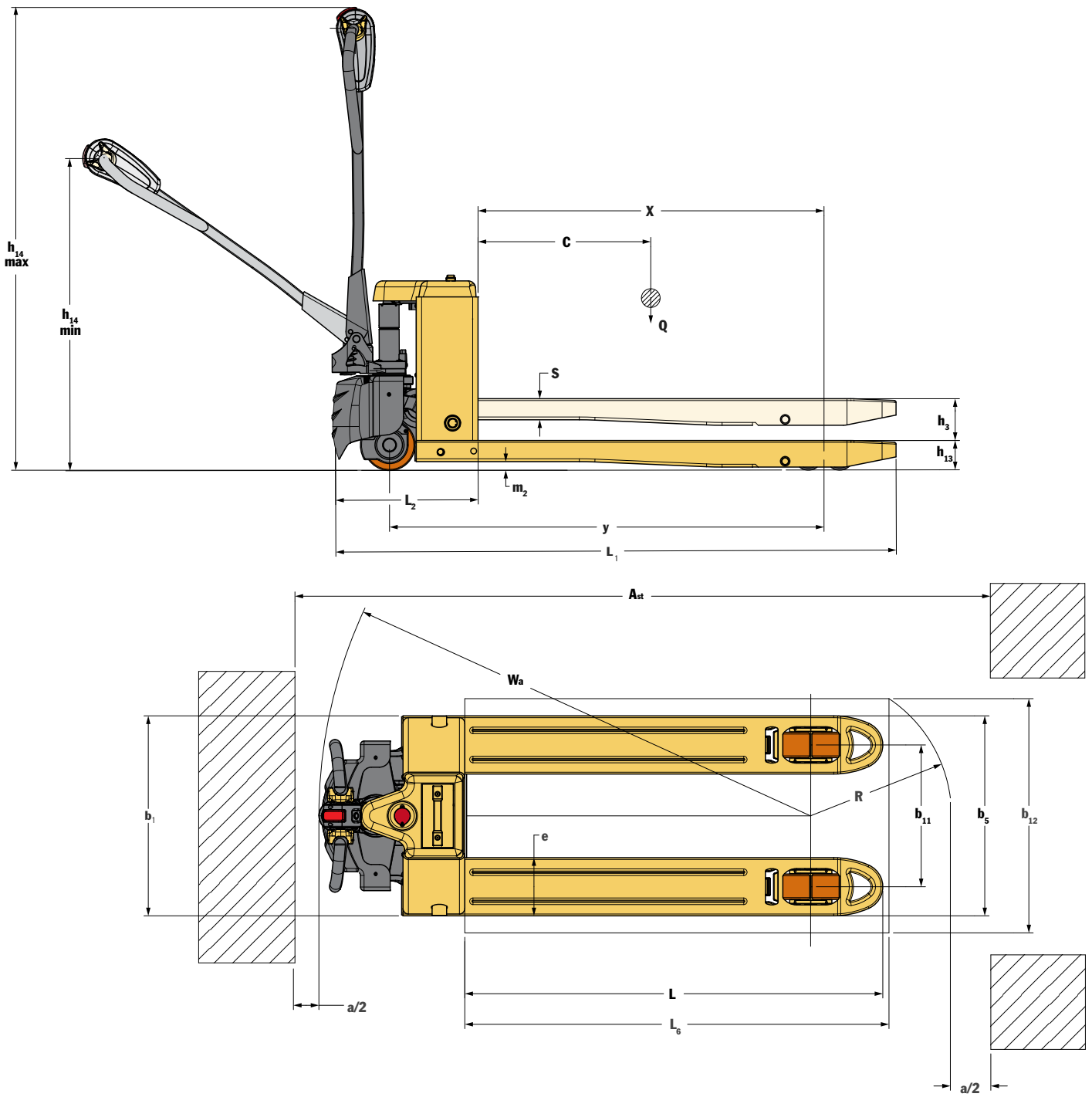

Specifications

MODEL		PPT20H	EPT15H	EPT20H	EPT15H-65L
CHARACTERISTICS					
1.1	Drive		Electric	Electric	Electric
1.2	Operator type		Pedestrian	Pedestrian	Pedestrian
1.3	Load capacity/rated load	Q kg	2000	1500	2000
1.4	Load centre	C mm	600	600	600
1.5	Height, fork lowered	h ₁₃ mm	82 ± 2	82 ± 2	82 ± 2
1.6	Wheelbase	y mm	1197/1267	1197/1267	1197/1267
1.7	Wheel		PU	PU	PU
1.8	Wheel size, front	mm	140*55	140*55	140*55
1.9	Wheel size, rear	mm	80*93 (Single Wheel)	80*93 (Single Wheel)	80*93 (Single Wheel)
		mm	80*70 (Tandem)	80*70 (Tandem)	80*70 (Tandem)
1.10	Wheels, number front/rear (x = drive wheels)		1x+2/4	1x+2/4	1x+2/4
1.11	Lift	h ₃ mm	115	115	115
1.12	Height of tiller in drive position, min./max.	h ₁₄ mm	740/1220	740/1220	740/1220
1.13	Overall length	L ₁ mm	1552/1622	1552/1622	1552/1622
1.14	Fork Length	L mm	1150/1220	1150/1220	1150/1220
1.15	Overall width	b ₁ mm	550/685	550/685	550/685
1.16	Fork dimensions	mm	58/160/1150(1220)	58/160/1150(1220)	58/160/1150(1220)
1.17	Distance between fork-arms	b ₅ mm	550/685	550/685	550/685
1.18	Ground clearance, centre of wheelbase	mm	22/137(24/139)	22/137(24/139)	22/137(24/139)
1.19	Aisle width for pallets 1000x1200 crossways	A _{st} mm	2155/2226	2155/2226	2155/2226
1.20	Aisle width for pallets 800x1200 lengthways	A _{st} mm	2024/2064	2024/2064	2024/2064
1.21	Turning radius	Wa mm	1353/1426	1353/1426	1353/1426
PERFORMANCE					
2.1	Travel speed, laden/unladen	km/h	4.0/4.5	4.0/4.5	4.0/4.5
2.2	Lifting speed, laden/unladen	mm/s	/	18/23	18/23
2.3	Lowering speed, laden/unladen	mm/s	/	56/46	56/46
2.4	Max. gradeability, laden/unladen	%	6%/20%	6%/20%	6%/20%
2.5	Drive motor	kW	DC 1.0 Brushless	DC 0.75 Brushless	DC 1.0 Brushless
2.6	Lift motor	kW	Hydraulic	DC 0.8	DC 0.8
BATTERY					
3.1	Battery voltage/nominal capacity	V/Ah	48V/10Ah(48V/15Ah)	48V/10Ah(48V/15Ah)	48V/10Ah(48V/15Ah)
3.2	Traveling brake		Regenerate	Regenerate	Regenerate
3.3	Brake		Electromagnetic	Electromagnetic	Electromagnetic
3.4	Sound level at the driver's ear according to EN 12053	A	< 70dB	< 70dB	< 70dB
3.5	Service weight including battery	kg	117/123.5	116.5/123	119/125.5